

# TECHNICAL DATA

# K-70

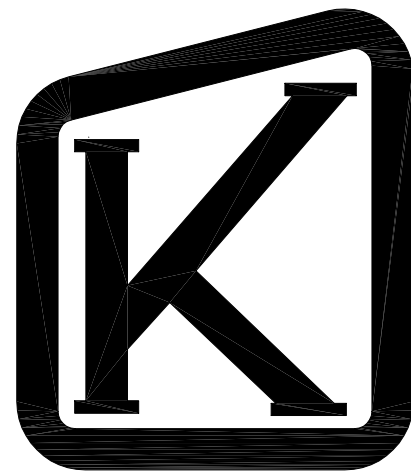
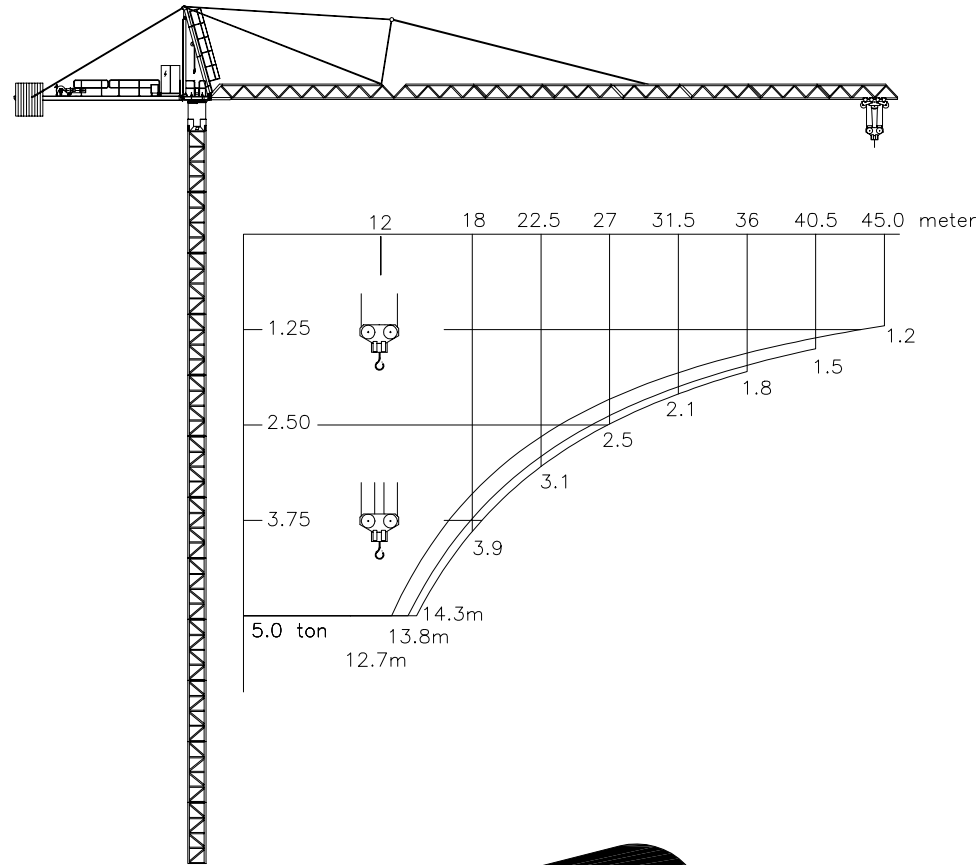

⚡	3 x 400 V - 50 Hz	CONTROL VOLTAGE / STEUER SPANNUNG
	3 x 440 V - 60 Hz	24 VDC - 220 VAC

HOIST WINCH / HUBWERK	30 kW
POWER CONSUMPTION / STROMVERBRAUCH	50 kVA
FUSE / SICHERUNG	100 Amps
POWER CABLE	4G35
HAUPTKABEL	4G50

0-1250 kg	0 - 120 m/min
0-2500 kg	0 - 60 m/min

0-2500 kg	0 - 60 m/min
0-5000 kg	0 - 30 m/min

	1 x 5 kW	MAX JIB MAX AUSLEGER	0 - 1.0 RPM
	2.2 kW	5 t	0 - 60 m/min
	4 x 5 kW	F <sub>max</sub>	25 m/min

HOIST ROPE HUB-SEIL	ø12 mm - FILL FACTOR 0.65 - 1770 MPa BREAKING STRESS 30 kW HOIST WINCH 150 m >150 m *	BRUCHSPANNUNG
TROLLEY ROPE LAUFKATZE-SEIL	ø8 mm	

\* CONSULT KRÖLL CRANES A/S - NEHMEN SIE MIT KRÖLL CRANES A/S KONTAKT AUF

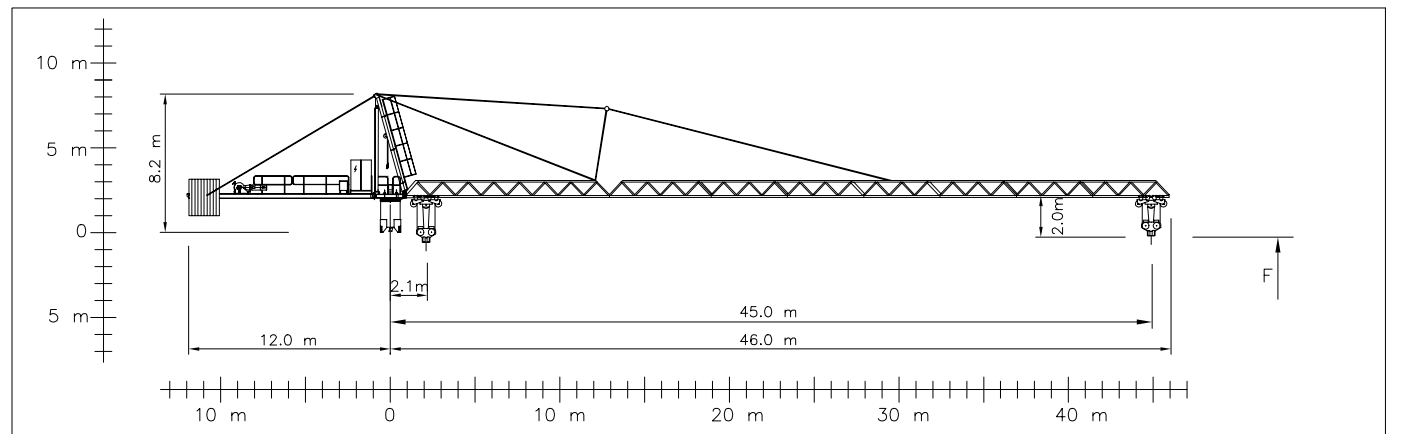

**APPROX. ERECTION WEIGHTS  
UNGEFÄHRE MONTAGEGEWICHTE**

JIB	L - kg	POS	ITEM	kg	POS	ITEM	kg
45.0	2610	1	TOWER/SLEW	3500	6	B12	2050
40.5	2290	2	CABIN	580	7	4.5m BX	1225
36.0	1970	3	REAR JIB	3300	8	N12	600
31.5	1650	3.1	WINCHES	1000	9	BASE PADS (4)	360
27.0	1270	4	INNER SECTION	1070	10	CT12	3600
22.5	950	5	M12 MAST	1250			

**EXTRA EQUIPMENT AVAILABLE**  
WALL TIE FRAMES, CABLE DRUMS, CURVE RUNNING AND 90° TURN BOGIES, ELEVATOR, FLOOD LIGHTING

**ZUSÄTZLICHE AUSRÜSTUNG VERFÜGBAR**  
EINSPANNRAHMEN, KABELTROMMEL, KURVENFAHRENDE UND 90° DREHSCHEMEL, AUFZUG, SCHEINWERFER

THE DESIGN AND TECHNICAL SPECIFICATIONS GIVEN ARE APPLICABLE TO THE STANDARD MACHINE OF CRANE K-70. MODIFICATIONS ACCORDING TO SPECIAL REQUIREMENTS REGARDING FOR EXAMPLE HOOK HEIGHT, JIB LENGTH, RAIL GAUGE, ETC.. ARE AVAILABLE. PLEASE CONTACT KRÖLL CRANES A/S

DIE KONSTRUKTIONS- UND TECHNISCHEN DATEN BEZIEHEN SICH AUF DIE STANDARD AUSFÜHRUNG DES KRANTYPS K-70. INDIVIDUELLE FORDERUNGEN Z.B AN HAKENHÖHE, AUSLEGERLÄNGE, SPURWEITE USW. KÖNNEN BERÜCKSICHTIGT WERDEN. NEHMEN SIE MIT KRÖLL CRANES A/S KONTAKT AUF

## KRÖLL CRANES A/S

Nordkranvej 2 · DK-3540 Lyngge · Denmark · Phone: +45 48 187400 · Fax: +45 48 188807

E-mail: krollcranes@krollcranes.dk · www.krollcranes.com

CONVERSION OF THE UNITS FOR FORCES UMRECHNUNG DER EINHEITEN FÜR KRÄFTE	10 N = 1 kg 10 kN = 1 ton	SUBJECT TO ALTERATIONS ÄNDERUNGEN VORBEHALTEN	DIN	DATA SHEET DATABLATT	K-70 010401
---	------------------------------	--	-----	-------------------------	----------------

# K-70 ON RAILS / AUF SCHIENEN

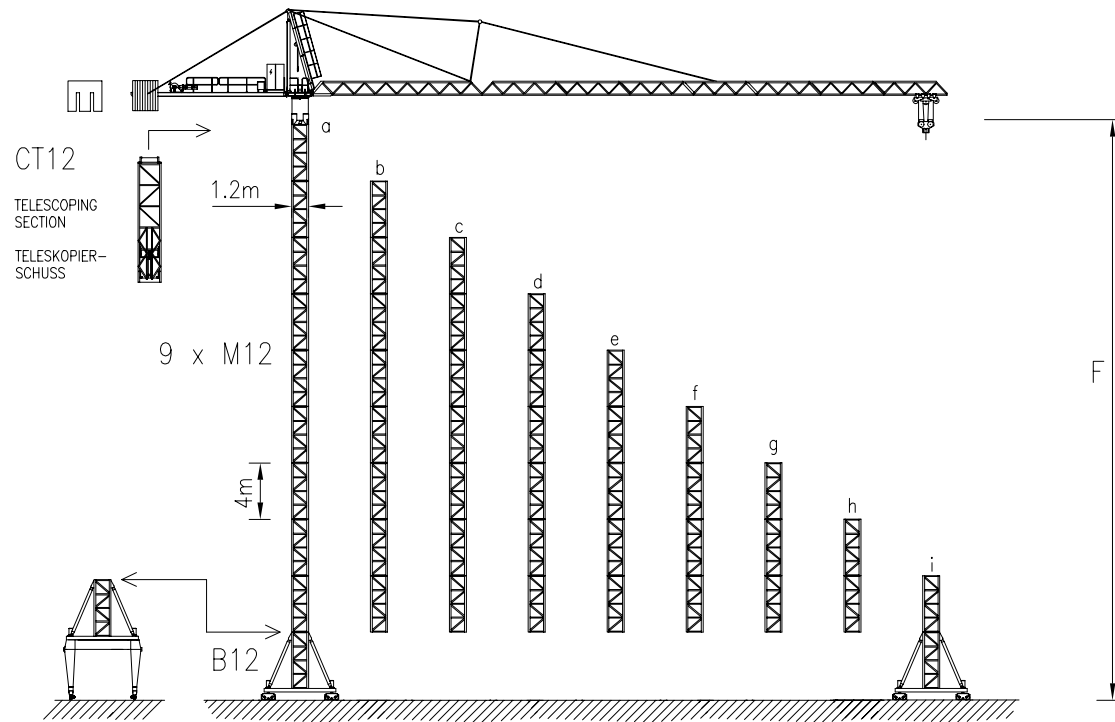

		a	b	c	d	e	f	g	h	i	
HOOK HEIGHT / HAKENHÖHE	F	m	41	37	33	29	25	21	17	13	9
RAIL GAUGE SPURWEITE	m	4.5									
BALLAST	t	46	35	26	18	15	15	15	15	15	15
PARKING FOUNDATIONS PARKIERUNGSFUNDAMENTE x4	t	0	0	0	0	0	0	0	0	0	0
CORNER PRESSURE ECKDRUCK	IN SERVICE IM BETRIEB	kN	430	380	330	290	260	250	240	220	210
	OUT OF SERVICE AUSSER BETRIEB	kN	480	380	290	230	190	180	170	170	160

# K-70 STATIONARY / STATIONÄR

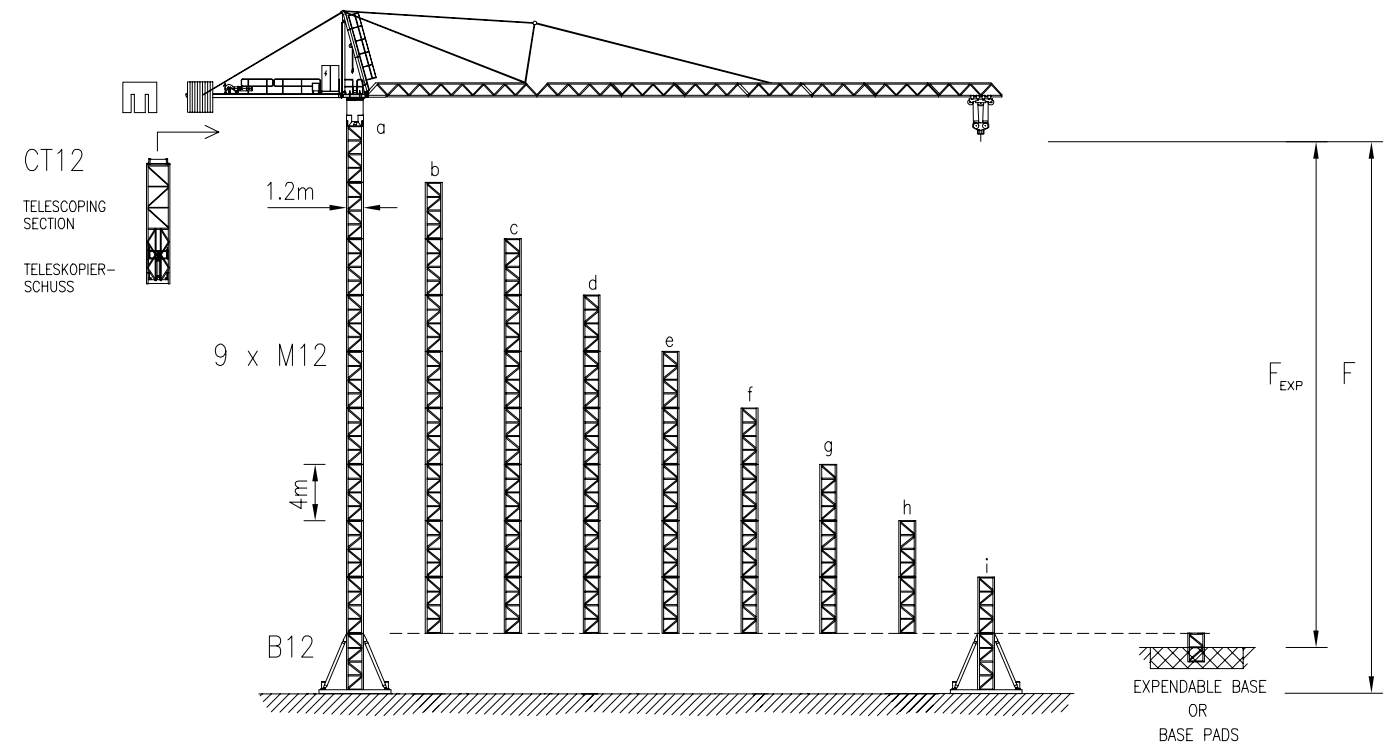

		a	b	c	d	e	f	g	h	i		
HOOK HEIGHT / HAKENHÖHE	F	m	40	36	32	28	24	20	16	12	8	
BALLAST	t	49	38	30	22	16	15	15	15	15	15	
CORNER PRESSURE ECKDRUCK	IN SERVICE IM BETRIEB	kN	390	340	300	270	240	220	210	200	190	
	OUT OF SERVICE AUSSER BETRIEB	kN	470	370	280	220	180	160	160	160	150	
FOUNDATION WEIGHT FUNDAMENTSGEWICHT	B x B x H	F	m	40	36	32	28	24	20	16	12	8
	H=1.0m	B	m	5.3	5.0	5.0	5.0	5.0	5.0	5.0	5.0	5.0
	min 200 kN/m <sup>2</sup>	ton	67	60	60	60	60	60	60	60	60	60
FOUNDATION WEIGHT FUNDAMENTSGEWICHT	B x B x H	F_EXP	m	36	32	28	24	20	16	12	8	
	H=1.4m	B	m	4.7	4.3	4.0	4.0	4.0	4.0	4.0	4.0	
	min 200 kN/m <sup>2</sup>	ton	74	62	54	54	54	54	54	54	54	

# K-70 CLIMBER / KLETTERKRAN

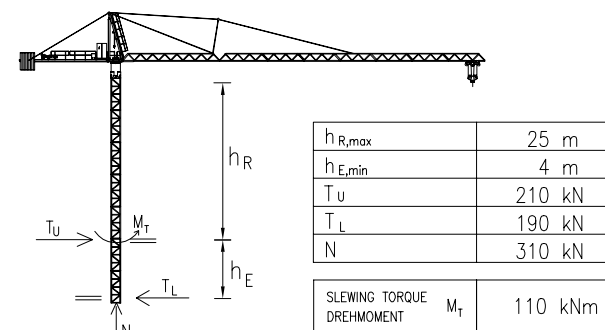
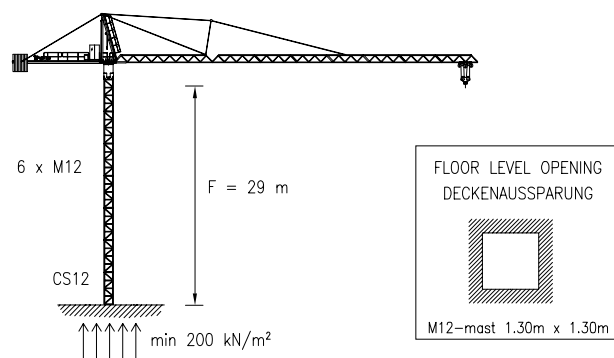

## JIB CONFIGURATION

JIB LENGTH AUSLEGER-LÄNGE	INNER SECTION	MIDDLE	MIDDLE	EYE SECTION	MIDDLE	INNER STAY INNERE ZUGSTANG			OUTER STAY ÄUSSERE ZUGSTANG			COUNTERWEIGHT GEGENGEWICHT		
						mm	mm	mm	mm	mm	mm	mm	kg	kg
45.0 m	1	1	2	1	3	1	1	2	12240	9600	4300	1510	500	8.0
40.5 m	1	1	2	1	2	1	1	2	12240	9600	4300	1510	500	6.5
36.0 m	1	1	2	1	1	1	1	2	12240	9600	4300	1510	500	5.5
31.5 m	1	1	2	1	0	1	1	2	12240	9600	4300	1510	500	4.5
27.0 m	1	1	1	1	0	1	1	1	12240	9600	4300	1510	500	3.5
22.5 m	1	1	0	1	0	1	1	0	12240	9600	4300	1510	500	3.0
12.0 m	1	0	0	0	0	1	1	0	12240	9600	4300	1510	500	2.0