



# MC285CB-3

## Fully Electric Powered Mini Crawler Crane



Crane Capacity	Max Working Radius	Max Lifting Height
<b>6210 lb x 4.5 ft</b> (2.82t x 1.4m)	<b>26.9 ft x 330 lb</b> (8.205m x 0.15t)	<b>28.54 ft</b> (8.7m)

- Compact & Light Weight
- Swing Angle Limit Setting
- Multi Position Outrigger Mode
- Wireless Radio Remote Control
- 4 Parts / 2 Parts Hook Block

- Lithium-ion Battery
- High Capacity Battery With Long Life
- Minimal Charging Time
- Continuous Operation While Charging



Programmable Moment Limiter



Eco modes



Paddle Lever  
Wireless Remote Control



Searcher Hook (Option)



# Zero Emissions

Specifications

Model		MC285CWMB-3US	
Crane capacity		6210lb x 4.5ft (2.82t x 1.4m)	
Max working radius		26.9ft x 330lb (8.205m x 0.15t)	
Max lifting height (on the ground)		28.54ft (8.7m)	
Max lifting height (underground)		-33.0ft (-10.1m) [4 parts of line]	
Winch system	Hook speed	30.5ft/min (9.3m/min) [4 layers, 4 parts of line]	
	Hoist wire rope	IWRC 6 x Fi (29) 7mm x 157.4ft (48m)	
Telescoping system	Type	Fully automatic 5-section pentagonal telescopic boom (3 to 5 section : simultaneous telescoping)	
	Boom length	8.3ft - 28.1ft (2.535m - 8.575m)	
	Boom telescoping stroke / time	19.8ft (6.04m) / 22sec	
Boom hoist system	Hoist angle / time	0 to 80deg / 14.0sec	
Swinging system	Swing angle / time	360deg / 0.88rpm	
Outrigger system	Type	1st stage with flexible stay damper, 2nd stage manual pullout hydraulic cylinder direct acting type	
	Max. extended width (between outside of OR adapters)	(Lateral) 15.69ft x (Front) 15.48ft x (Rear) 13.09ft (4782mm x 4718mm x 3990mm)	
Travel system	Type	Hydraulic motor driven , stepless speed changer	
	Travel speed	Forward / backward : 0 - 1.24mph (0 - 2.0km/h)	
	Gradability	20deg	
	Crawler ground length x width	3.2ft x 0.65ft (975mm x 200mm)	
Ground pressure		7.40PSI (51.0kPa)	
Battery system	Type	Lithium Titanate Battery	
	5-hour rate capacity	DC55V - 135Ah, 10.06hph (7.5kWh)	
	Input Voltage / current	Single-phase 100V/15A, 200V/16A	
	Charging time	(with AC-230V)	80% : 2h20min / 100% : 3h30min
		(with AC-115V)	80% : 5h20min / 100% : 7h00min
	Operating time	Travelling (Hi speed)	Up to 2h15min
Crane		Up to a full working day if charged during operation	
Charging during operation		Available	
Motor	Rated output	10.06hp SAE / 2500RPM (7.5kW AC 30V/2500min <sup>-1</sup> )	
Remote control system	Type	Radio & paddle type control	
Overall length x width x height		9.19 x 2.46 x 4.82ft (2800 x 750 x 1470mm)	
Machine weight		4400lb (1995kg)	
Safety device		Anti two block, Angle indicator, Hydraulic safety valve, Level, Machine body inclination alarm, EMO switch, Moment limiter, Working status lamp, Data logger, Crane & Outrigger interlock device, Travel Alarm	
Options		Black rubber tracks, Single part hook, 1870lb searcher hook	

Fully Electric Powered Mini Crawler Crane

# MC285CB-3



Rated Total Load Chart (4 Parts)

MAXIMUM Outriggers, 4 Parts Line					
Boom Length	8.3 Ft.	8.4 - 13.3 Ft.	13.4 - 18.2 Ft.	18.3 - 23.2 Ft.	23.3 - 28.1 Ft.
Radius (Ft.)	Load (Lbs.)	Load (Lbs.)	Load (Lbs.)	Load (Lbs.)	Load (Lbs.)
4.5	6210	6210	2630		
5.0	5490	5490	2630		
6.5	4280	4280	2630	1800	
7.0	4020	4020	2630	1800	1210
8.0		3550	2630	1800	1210
10.0		2630	2630	1800	1210
11.5		2130	2130	1800	1210
11.8		2080	2050	1800	1210
12.0		2050	2000	1780	1210
13.0			1750	1650	1210
15.0			1350	1240	860
16.5			1160	1050	750
17.0			1160	1010	710
18.0				950	660
20.0				820	570
21.0				780	520
21.9				730	480
23.0					440
25.0					380
26.9					330

OTHER THAN MAXIMUM Outriggers, 4 Parts Line					
Boom Length	8.3 Ft.	8.4 - 13.3 Ft.	13.4 - 18.2 Ft.	18.3 - 23.2 Ft.	23.3 - 28.1 Ft.
Radius (Ft.)	Load (Lbs.)	Load (Lbs.)	Load (Lbs.)	Load (Lbs.)	Load (Lbs.)
4.5	3790	3790	1100		
5.0	3720	3720	1100		
6.5	2410	2410	1100	880	
7.0	2100	2100	1100	880	720
8.0		1500	1100	880	720
10.0		1110	1100	880	720
11.5		850	900	880	720
11.8		810	870	880	720
12.0		790	850	860	720
13.0			750	750	720
15.0			590	600	600
16.5			440	500	500
17.0			440	450	450
18.0				400	400
20.0				340	340
21.0				300	300
21.9				260	260
23.0					220
25.0					170
26.9					130

\* The Rated Total Load Chart is based on actual working radius including boom deflection.  
 \* The weight of hook block (standard 4 parts / 2 parts-66lb) must be included as part of the load shown in the Rated Total Load Chart.  
 \* When using two parts hook or single part hook, use the appropriate four parts Rated Total Load Chart shown above but with a maximum load of : -3100lb for two parts and -1560lb for Single part.

Dimensions

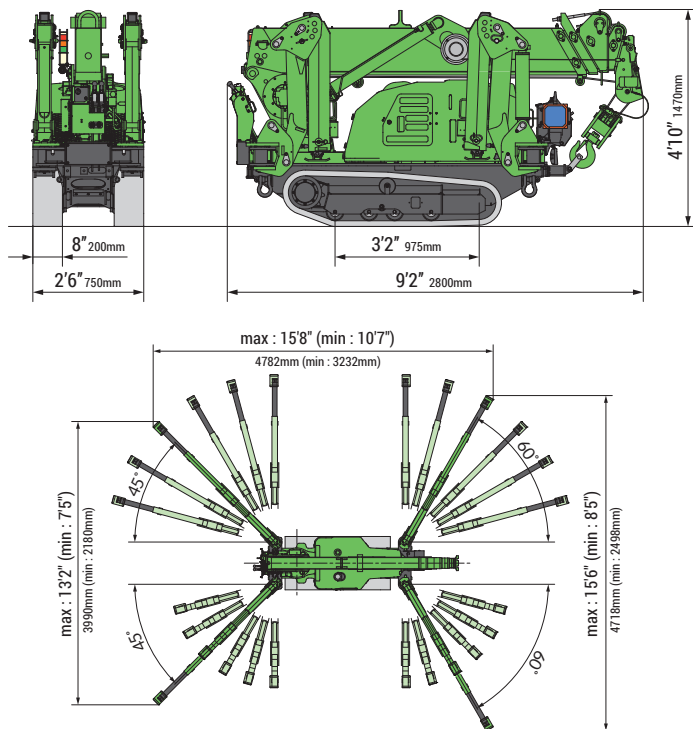

MAX Reach Below Grade

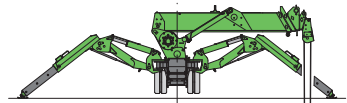

Working Range Chart (4 Parts)

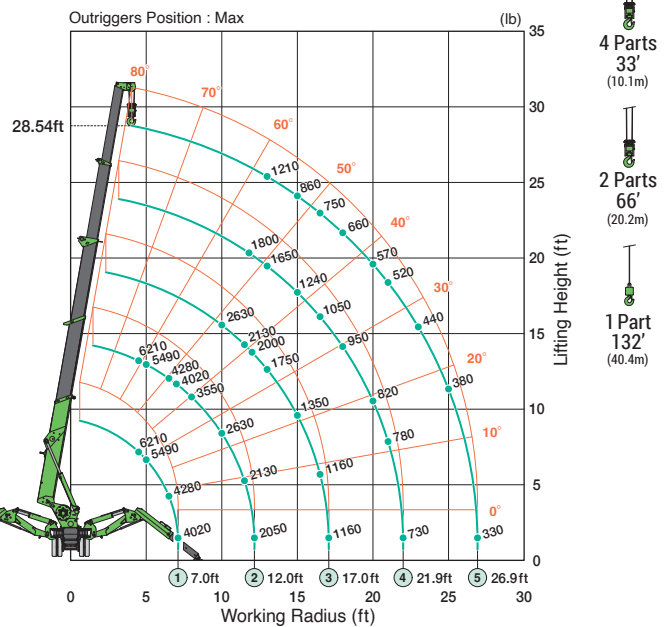

ASME B 30.5 compliant



Tel: (817) 984-8516 Email: minicranes@maedaamerica.com URL: maedaamerica.com



⚠ Before use, please read the Operation Manual

\* Due to improvements, the specifications are subject to change without notice.